

**Перфорированные кабельные лотки предварительной оцинковки (PG)**

Наименование		A:	e:	Ед.	h:	L: (мм)	Вес
1	TSTK-A10, TSTK-B10, TSTK-C10 PG, Перфорированный кабельный Лоток	100 мм	0,7	метр	50	3000	1,225
					60	3000	1,470
					100	3000	2,040
			0,8	метр	50	3000	1,400
					60	3000	1,680
					100	3000	2,550
			1	метр	50	3000	1,750
					60	3000	2,100
					100	3000	2,550
2	TSTK-A20, TSTK-B20, TSTK-C20 PG, Перфорированный кабельный Лоток	200 мм	0,8	метр	50	3000	2,040
					60	3000	2,448
					100	3000	2,640
			1	метр	50	3000	2,550
					60	3000	3,060
					100	3000	3,300
			1,2	метр	50	3000	3,060
					60	3000	3,672
					100	3000	3,960
3	TSTK-A30, TSTK-B30, TSTK-C30 PG, Перфорированный кабельный Лоток	300 мм	0,8	метр	50	3000	2,680
					60	3000	3,216
					100	3000	3,280
			1	метр	50	3000	3,350
					60	3000	4,020
					100	3000	4,100
			1,2	метр	50	3000	4,020
					60	3000	4,824
					100	3000	4,920
4	TSTK-A40, TSTK-B40, TSTK-C40 PG, Перфорированный кабельный Лоток	400 мм	1	метр	50	3000	4,150
					60	3000	4,773
					100	3000	4,900
			1,2	метр	50	3000	4,980
					60	3000	5,727
					100	3000	5,880
			1,5	метр	50	3000	6,250
					60	3000	7,188
					100	3000	7,350
			2	метр	50	3000	8,300
					60	3000	9,545
					100	3000	9,800
5	TSTK-A50, TSTK-B50, TSTK-C50 PG, Перфорированный	500 мм	1	метр	50	3000	4,950
					60	3000	5,445
					100	3000	5,700
			1,2	метр	50	3000	5,940
					60	3000	6,534
					100	3000	6,840

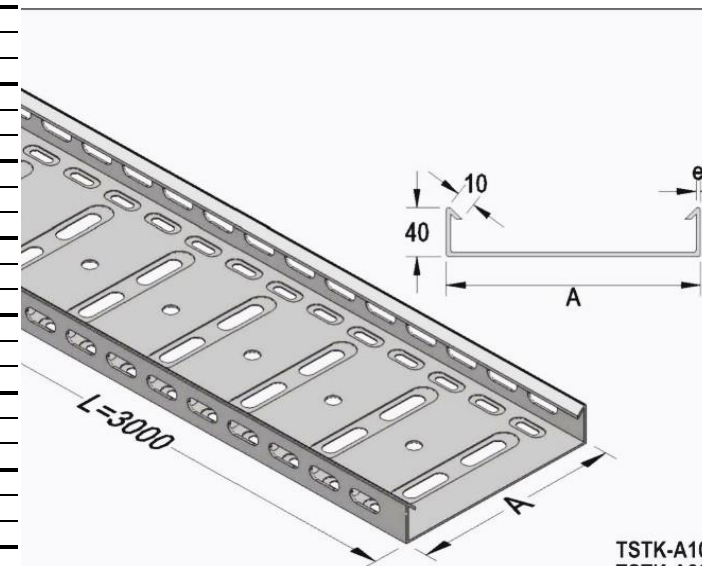

TSTK-A10  
TSTK-A20  
TSTK-A30

	кабельный Лоток	500 мм	1,5	метр	50	3000	7,450
					60	3000	8,195
					100	3000	8,500
			2	метр	50	3000	9,900
					60	3000	10,890
					100	3000	11,400

Усиленные перфорированные кабельные лотки предварительной оцинковки (PG)									
	Наименование	A:	e:	Ед.	h:	L: (мм)	Вес		
6	TSKT-A5 PG, TSTK-B5 PG, Перфорированный кабельный Лоток	50 мм	0,7	метр	50	3000	0,868		
					60	3000	1,042		
			0,8	метр	50	3000	0,992		
					60	3000	1,190		
			1	метр	50	3000	1,240		
					60	3000	1,488		
		7	TSKT-A10 PG, TSTK-B10, TSTK-C10 PG, Перфорированный кабельный Лоток	100 мм	0,7	метр	50	3000	1,225
							60	3000	1,470
					0,8	метр	50	3000	1,400
60	3000						1,680		
1	метр				100	3000	2,040		
					50	3000	1,750		
60	3000			2,100					
	100			3000	2,550				
	8			TSKT-A20 PG, TSTK-B20, TSTK-C20 PG, Перфорированный кабельный Лоток	200 мм	0,8	метр	50	3000
60		3000	2,448						
100		3000	2,640						
1		метр	50		3000	2,550			
			60		3000	3,060			
			100		3000	3,300			
9	TSKT-A30 PG, TSTK-B30, TSTK-C30 PG, Перфорированный кабельный Лоток	300 мм	0,8	метр	50	3000	3,060		
					60	3000	3,672		
			100	3000	3,960				
		1	метр	50	3000	3,350			
				60	3000	4,020			
				100	3000	4,100			
1,2	метр	50	3000	4,020					
		60	3000	4,824					
		100	3000	4,920					
1	метр	50	3000	4,150					
		60	3000	4,773					
		100	3000	4,900					
					50	3000	4,980		

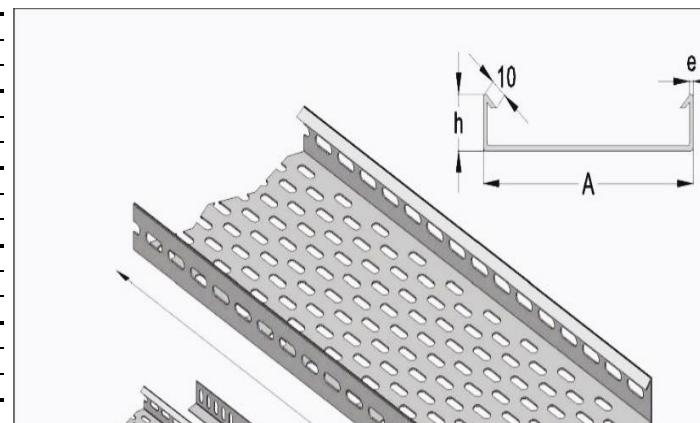

10	TSKT-A40 PG, TSTK-B40, TSTK-C40 PG, Перфорированный кабельный Лоток	400 мм	1,2	метр	60	3000	5,727
					100	3000	5,880
			1,5	метр	50	3000	6,250
					60	3000	7,188
			2	метр	100	3000	7,350
					50	3000	8,300
		60	3000	9,545			
		100	3000	9,800			
11	TSKT-A50 PG, TSTK-B50, TSTK-C50 PG, Перфорированный кабельный Лоток	500 мм	1	метр	50	3000	4,950
					60	3000	5,445
					100	3000	5,700
			1,2	метр	50	3000	5,940
					60	3000	6,534
					100	3000	6,840
			1,5	метр	50	3000	7,450
					60	3000	8,195
					100	3000	8,500
			2	метр	50	3000	9,900
					60	3000	10,890
					100	3000	11,400
12	TSKT-A60 PG, TSTK-B60, TSTK-C60 PG, Перфорированный кабельный Лоток	600 мм	1	метр	50	3000	5,700
					60	3000	6,270
					100	3000	6,840
			1,2	метр	50	3000	6,840
					60	3000	7,524
					100	3000	8,208
			1,5	метр	50	3000	8,550
					60	3000	9,405
					100	3000	10,260
			2	метр	50	3000	12,408
					60	3000	13,401
					100	3000	13,773

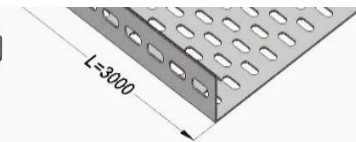
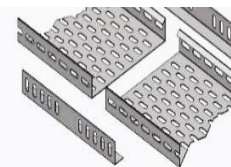

TSKT-A/5

**Аксессуары: Горизонтальный угол 90° (PG)**

Наименование		A:	e:	Ед.	h:	Вес
13	TSD-A5/5, TSD-B5 PG, Горизонтальный угол 90°	50 мм	1	шт.	50	0,660
					60	0,792
			1,2	шт.	50	0,792
					60	0,950
			1,5	шт.	50	0,990
					60	1,426
14	TSD-A10/5, TSD-B10, TSD-C10 PG, Горизонтальный угол 90°	100 мм	1	шт.	50	0,767
					60	0,900
					100	1,100
			1,2	шт.	50	0,920
					60	1,080
					100	1,320

			1,5	шт.	50	1,150		
					60	1,350		
					100	1,650		
15	TSD-A20/5, TSD-B20, TSD-C20 PG, Горизонтальный угол 90°	200	1	шт.	50	1,320		
					60	1,467		
					100	1,600		
					1,2	шт.	50	1,584
				60			1,760	
				100			1,920	
				1,5	шт.	50	1,980	
						60	2,200	
						100	2,400	
16	TSD-A30/5, TSD-B30, TSD-C30 PG, Горизонтальный угол 90°	300	1,2	шт.	50	2,310		
					60	2,610		
					100	2,820		
				1,5	шт.	50	2,888	
						60	3,263	
						100	3,525	
				2	шт.	50	3,850	
						60	4,350	
						100	4,700	
17	TSD-A40/5, TSD-B40, TSD-C40 PG, Горизонтальный угол 90°	400	1,2	шт.	50	3,480		
					60	4,380		
					100	5,280		
				1,5	шт.	50	4,350	
						60	5,475	
						100	6,600	
				2	шт.	50	5,800	
						60	7,300	
						100	8,800	
18	TSD-A50/5, TSD-B50, TSD-C50 PG, Горизонтальный угол 90°	500	1,2	шт.	50	4,770		
					60	5,460		
					100	6,120		
				1,5	шт.	50	5,963	
						60	6,825	
						100	7,650	
				2	шт.	50	7,950	
						60	9,100	
						100	10,200	
19	TSD-A60/5, TSD-B60, TSD-C60 PG, Горизонтальный угол 90°	600	1,2	шт.	50	6,450		
					60	6,840		
					100	7,140		
				1,5	шт.	50	8,063	
						60	8,550	
						100	8,925	
				2	шт.	50	10,750	
						60	11,400	
						100	11,900	

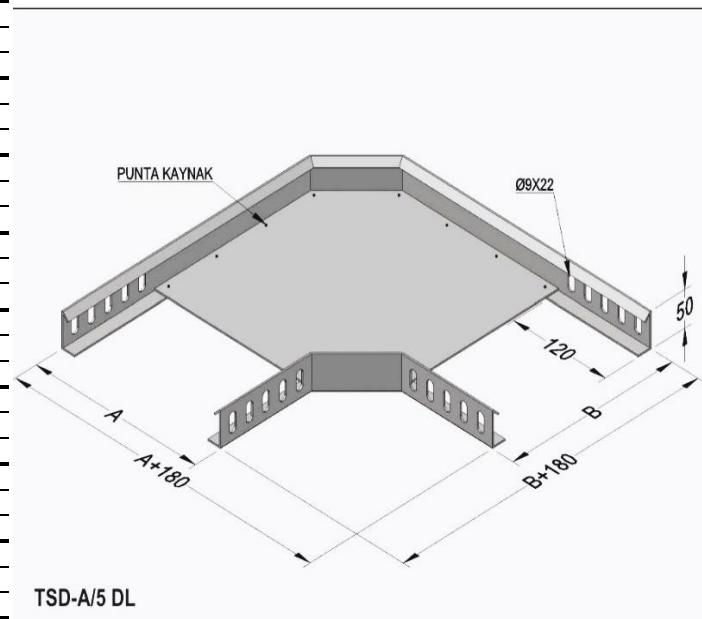

Аксессуары: Т-Образный элемент (PG)

	Наименование	A:	e:	Ед.	h:	Вес
20	TST-A5/5 PG, TST-B5 PG, T-Образный элемент	50 мм	1	шт.	50	0,710
					60	0,852
			1,2	шт.	50	0,852
					60	1,022
			1,5	шт.	50	1,065
					60	1,534
21	TST-A10/5, TST-B10, TST-C10 PG, T-Образный элемент	100 мм	1	шт.	50	0,907
					60	1,088
					100	1,447
			1,2	шт.	50	1,088
					60	1,306
					100	1,736
			1,5	шт.	50	1,360
					60	1,632
					100	2,170
22	TST-A20/5, TST-B20, TST-C20 PG, T-Образный элемент	200 мм	1	шт.	50	1,300
					60	1,560
					100	2,067
			1,2	шт.	50	1,560
					60	1,872
					100	2,480
			1,5	шт.	50	1,950
					60	2,340
					100	3,100
23	TST-A30/5, TST-B30, TST-C30 PG, T-Образный элемент	300 мм	1,2	шт.	50	2,268
					60	2,722
					100	3,270
			1,5	шт.	50	2,835
					60	3,402
					100	4,088
			2	шт.	50	3,780
					60	4,536
					100	5,450
24	TST-A40/5, TST-B40, TST-C40 PG, T-Образный элемент	400 мм	1,2	шт.	50	3,210
					60	3,852
					100	4,320
			1,5	шт.	50	4,013
					60	4,815
					100	5,400
			2	шт.	50	5,350
					60	6,420
					100	7,200
			1,2	шт.	50	4,290
					60	4,719
					100	5,340
					50	5,363

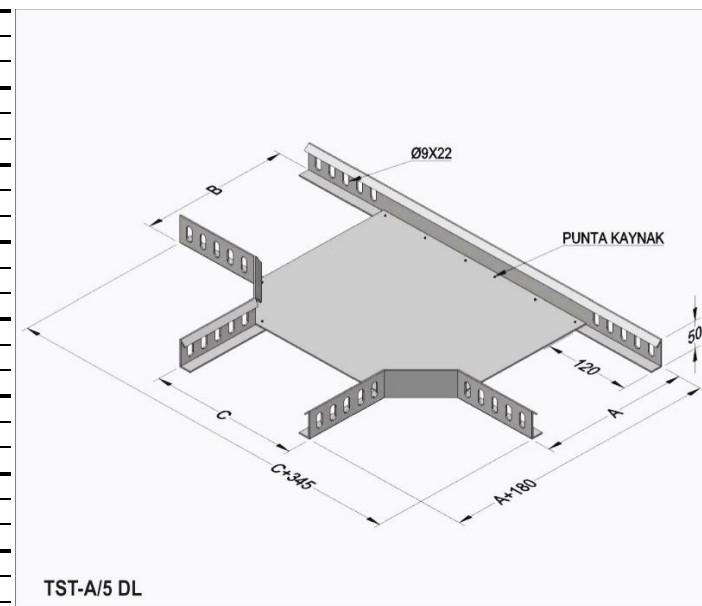

25	TST-A50/5, TST-B50, TST-C50 PG, T-Образный элемент	500 мм	1,5	шт.	60	5,899
					100	6,675
			2	шт.	50	7,150
					60	7,865
					100	8,900
			26	TST-A60/5, TST-B60, TST-C60 PG, T-Образный элемент	600 мм	1,2
60	6,171					
100	6,750					
1,5	шт.	50				7,013
		60				7,714
		100				8,438
2	шт.	50				9,350
		60				10,285
		100				11,250

**Аксессуары: Кресто-образный элемент (PG)**

Наименование		A:	e:	Ед.	h:	Вес			
27	TSDB-A5/5, TSDB-B5 PG, Кресто-образный элемент	50 мм	1	шт.	50	0,900			
					60	1,080			
			1,2	шт.	50	1,080			
					60	1,296			
			1,5	шт.	50	1,350			
					60	1,944			
28	TSDB-A10/5, TSDB-B10, TSDB-C10 PG, Кресто-образный элемент	100 мм	1	шт.	50	1,000			
					60	1,167			
					100	1,333			
			1,2	шт.	50	1,200			
					60	1,400			
					100	1,600			
			1,5	шт.	50	1,500			
					60	1,750			
					100	2,000			
			29	TSDB-A20/5, TSDB-B20, TSDB-C20 PG, Кресто-образный элемент	200 мм	1	шт.	50	1,533
								60	1,840
								100	2,267
1,2	шт.	50				1,840			
		60				2,208			
		100				2,720			
1,5	шт.	50	2,300						
		60	2,760						
		100	3,400						
30	TSDB-A30/5, TSDB-B30, TSDB-C30 PG, Кресто-образный элемент	300 мм	1,2	шт.	50	2,610			
					60	3,132			
					100	3,390			
			1,5	шт.	50	3,263			
					60	3,915			
					100	4,238			

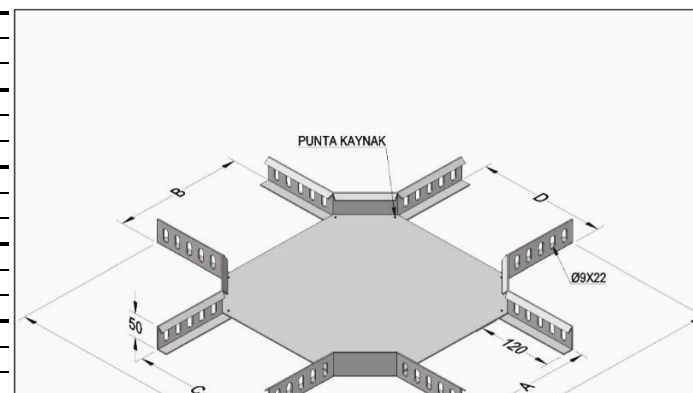

			2	шт.	50	4,350
					60	5,220
					100	5,650
31	TSDB-A40/5, TSDB-B40, TSDB-C40 PG, Кресто-образный элемент	400 мм	1,2	шт.	50	4,170
					60	4,320
					100	4,380
			1,5	шт.	50	5,213
					60	5,400
					100	5,475
			2	шт.	50	6,950
					60	7,200
					100	7,300
32	TSDB-A50/5, TSDB-B50, TSDB-C50 PG, Кресто-образный элемент	500 мм	1,2	шт.	50	4,800
					60	5,040
					100	5,280
			1,5	шт.	50	6,000
					60	6,300
					100	6,600
			2	шт.	50	8,000
					60	8,400
					100	8,800
33	TSDB-A60/5, TSDB-B60, TSDB-C60 PG, Кресто-образный элемент	600 мм	1,2	шт.	50	6,000
					60	6,300
					100	6,600
			1,5	шт.	50	7,500
					60	7,875
					100	8,250
			2	шт.	50	10,000
					60	10,500
					100	11,000



TSDB-A/5 DL

**Крепёжный элемент: Соединительный элемент лотка (PG)**

Наименование		A:	e:	Ед.	h:	L: (мм)	Вес
34	TS1-3, TS1-4, TS1-5 PG, Соединительный элемент лотка	23 мм	1,5	шт.	50	250	0,180
					60	250	0,308
					100	250	0,420
			2	шт.	50	250	0,240
					60	250	0,410
					100	250	0,560

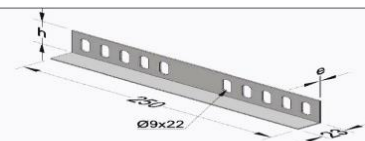

TS1 DL  
TS2 DL

**Аксессуары: Горизонтальный угол 90° радиус 300° (PG)**

Наименование		A:	e:	Ед.	h:	Вес
35	TSD-A5/5 300R, TSD-B5 300R PG, Горизонтальный угол 90° радиус 300°	50 мм	1	шт.	50	0,940
					60	1,250
			1,2	шт.	50	1,128
					60	1,500

			1,5	шт.	50	1,410
					60	1,875
36	TSD-A10/5 300R, TSD-B10 300R, TSD-C10 300R PG, Горизонтальный угол 90° радиус 300°	100 мм	1	шт.	50	1,100
					60	1,160
					100	1,460
			1,2	шт.	50	1,320
					60	1,392
					100	1,752
			1,5	шт.	50	1,650
					60	1,740
					100	2,190
37	TSD-A20/5 300R, TSD-B20 300R, TSD-C20 300R PG, Горизонтальный угол 90° радиус 300°	200 мм	1	шт.	50	1,690
					60	1,770
					100	2,140
			1,2	шт.	50	2,028
					60	2,124
					100	2,568
			1,5	шт.	50	2,535
					60	2,655
					100	3,210
38	TSD-A30/5 300R, TSD-B30 300R, TSD-C30 300R PG, Горизонтальный угол 90° радиус 300°	300 мм	1,2	шт.	50	2,910
					60	2,950
					100	3,750
			1,5	шт.	50	3,638
					60	3,688
					100	4,688
			2	шт.	50	4,838
					60	4,904
					100	6,234
39	TSD-A40/5 300R, TSD-B40 300R, TSD-C40 300R PG, Горизонтальный угол 90° радиус 300°	400 мм	1,2	шт.	50	3,900
					60	4,000
					100	4,480
			1,5	шт.	50	4,875
					60	5,000
					100	5,600
			2	шт.	50	6,484
					60	6,650
					100	7,448
40	TSD-A50/5 300R, TSD-B50 300R, TSD-C50 300R PG, Горизонтальный угол 90° радиус 300°	500 мм	1,2	шт.	50	5,200
					60	5,300
					100	11,700
			1,5	шт.	50	6,500
					60	6,625
					100	14,625
			2	шт.	50	8,645
					60	8,811
					100	19,451
			1,2	шт.	50	6,650
					60	6,700

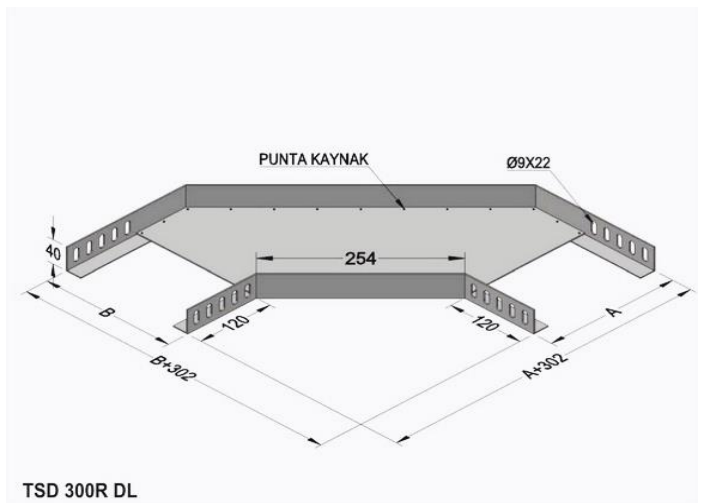



41	TSD-A60/5 300R, TSD-B60 300R, TSD-C60 300R PG, Горизонтальный угол 90° радиус 300°	600 мм	1,5	шт.	100	13,800
					50	8,313
					60	8,375
			2	шт.	100	17,250
					50	11,056
					60	11,139
					100	22,943

**Аксессуары: Т-образный элемент радиус 300° (PG)**

Наименование	A:	e:	Ед.	h:	Вес
TST-A5/5 PG, TST-B5 PG, Т-образный элемент, радиус 300°	50 мм	1	шт.	50	1,620
				60	1,720
		1,2	шт.	50	1,944
				60	2,064
		1,5	шт.	50	2,430
				60	2,580
TST-A10/5, TST-B10, TST-C10 PG, Т-образный элемент, радиус 300°	100 мм	1	шт.	50	1,860
				60	2,000
				100	2,450
		1,2	шт.	50	2,232
				60	2,400
				100	2,940
1,5	шт.	50	2,790		
		60	3,000		
		100	3,675		
TST-A20/5, TST-B20, TST-C20 PG, Т-образный элемент, радиус 300°	200 мм	1	шт.	50	2,800
				60	2,970
				100	3,550
		1,2	шт.	50	3,360
				60	3,564
				100	4,260
1,5	шт.	50	4,200		
		60	4,455		
		100	5,325		
TST-A30/5, TST-B30, TST-C30 PG, Т-образный элемент, радиус 300°	300 мм	1,2	шт.	50	4,550
				60	4,700
				100	5,400
		1,5	шт.	50	5,688
				60	5,875
				100	6,750
2	шт.	50	7,564		
		60	7,814		
		100	8,978		
		1,2	шт.	50	6,000
				60	6,200

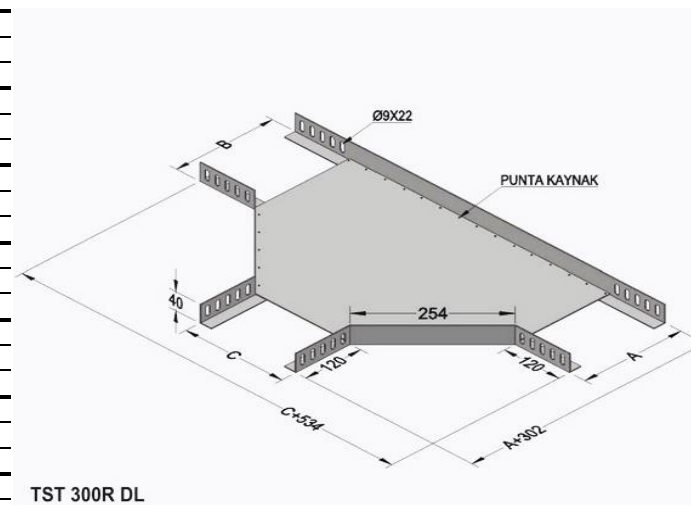

TST 300R DL

TST-A40/5, TST-B40, TST-C40 PG, T-Образный элемент, радиус 300°	400 мм	1,5	шт.	100	7,000		
				50	7,500		
				60	7,750		
		2	шт.	100	8,750		
				50	9,975		
				60	10,308		
		TST-A50/5, TST-B50, TST-C50 PG, T-Образный элемент, радиус 300°	500 мм	1,2	шт.	100	8,400
						50	9,338
						60	9,375
1,5	шт.			100	10,500		
				50	12,419		
				60	12,469		
2	шт.			100	13,965		
				50	9,270		
				60	9,330		
TST-A60/5, TST-B60, TST-C60 PG, T-Образный элемент, радиус 300°	600 мм	1,2	шт.	100	10,200		
				50	11,588		
				60	11,663		
		1,5	шт.	100	12,750		
				50	15,411		
				60	15,511		
		2	шт.	100	16,958		
				50			
				60			

Аксессуары: Внутренний (внешний) вертикальный угол. (PG)						
Наименование	A:	e:	Ед.	h:	Вес	
TSIB-A5/5, TSIB-B5 PG, Внутренний (внешний) вертикальный угол	50 мм	1	шт.	50	1,600	
				60	1,800	
		1,2	шт.	50	1,920	
				60	2,160	
		1,5	шт.	50	2,400	
				60	2,700	
TSIB-A10/5, TSIB-B10, TSIB-C10 PG, Внутренний (внешний) вертикальный угол	100 мм	1	шт.	50	2,300	
				60	2,400	
				100	2,500	
		1,2	шт.	50	2,760	
				60	2,880	
				100	3,000	
		1,5	шт.	50	3,450	
				60	3,600	
				100	3,750	
		1	шт.	50	2,800	
				60	2,900	

TSIB-A20/5, TSIB-B20, TSIB-C20 PG, Внутренний (внешний) вертикальный угол	200 мм	1,2	шт.	100	3,000
				50	3,360
				60	3,480
		1,5	шт.	100	3,600
				50	4,200
				60	4,350
		2	шт.	100	4,500
				50	4,410
				60	4,500
TSIB-A30/5, TSIB-B30, TSIB-C30 PG, Внутренний (внешний) вертикальный угол	300 мм	1,2	шт.	100	4,700
				50	5,513
				60	5,625
		1,5	шт.	100	5,875
				50	7,332
				60	7,481
		2	шт.	100	7,814
				50	8,229
				60	8,479
TSIB-A40/5, TSIB-B40, TSIB-C40 PG, Внутренний (внешний) вертикальный угол	400 мм	1,2	шт.	100	8,811
				50	9,490
				60	9,809
		1,5	шт.	100	10,141
				50	10,476
				60	10,809
		2	шт.	100	11,139
				50	11,471
				60	11,804
TSIB-A50/5, TSIB-B50, TSIB-C50 PG, Внутренний (внешний) вертикальный угол	500 мм	1,2	шт.	100	11,804
				50	12,500
				60	12,900
		1,5	шт.	100	13,400
				50	14,125
				60	14,625
		2	шт.	100	15,125
				50	15,976
				60	16,827
TSIB-A60/5, TSIB-B60, TSIB-C60 PG, Внутренний (внешний) вертикальный угол	600 мм	1,2	шт.	100	17,776
				50	18,700
				60	19,625
		1,5	шт.	100	20,625
				50	21,625
				60	22,625
		2	шт.	100	23,625
				50	24,750
				60	25,875

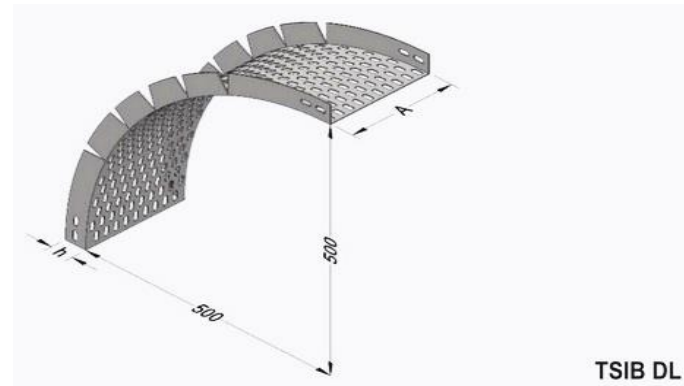

TSIB DL

**Аксессуары: Горизонтальный угол 45° (PG)**

Наименование	A:	e:	Ед.	h:	Вес
				50	0,470
		1	шт.	60	0,700

TSD-A5-45/5, TSD-B5-45 PG, Горизонтальный угол 45°	50 мм	1,2	шт.	50	0,564
				60	0,840
		1,5	шт.	50	0,705
				60	1,050
TSD-A10-45/5, TSD-B10-45, TSD-C10-45 PG, Горизонтальный угол 45°	100 мм	1	шт.	50	0,650
				60	1,200
				100	1,300
		1,2	шт.	50	0,780
				60	1,440
				100	1,560
		1,5	шт.	50	0,975
				60	1,800
				100	1,950
TSD-A20-45/5, TSD-B20-45, TSD-C20-45 PG, Горизонтальный угол 45°	200 мм	1	шт.	50	1,260
				60	1,400
				100	1,750
		1,2	шт.	50	1,512
				60	1,680
				100	2,100
		1,5	шт.	50	1,890
				60	2,100
				100	2,625
TSD-A30-45/5, TSD-B30-45, TSD-C30-45 PG, Горизонтальный угол 45°	300 мм	1,2	шт.	50	1,920
				60	2,000
				100	2,600
		1,5	шт.	50	2,400
				60	2,500
				100	3,250
		2	шт.	50	3,192
				60	3,325
				100	4,323
TSD-A40-45/5, TSD-B40-45, TSD-C40-45 PG, Горизонтальный угол 45°	400 мм	1,2	шт.	50	2,050
				60	2,400
				100	3,240
		1,5	шт.	50	2,563
				60	3,000
				100	4,050
		2	шт.	50	3,408
				60	3,990
				100	5,387
TSD-A50-45/5, TSD-B50-45, TSD-C50-45 PG, Горизонтальный угол 45°	500 мм	1,2	шт.	50	3,350
				60	3,500
				100	3,900
		1,5	шт.	50	4,188
				60	4,375
				100	4,875
				50	5,569

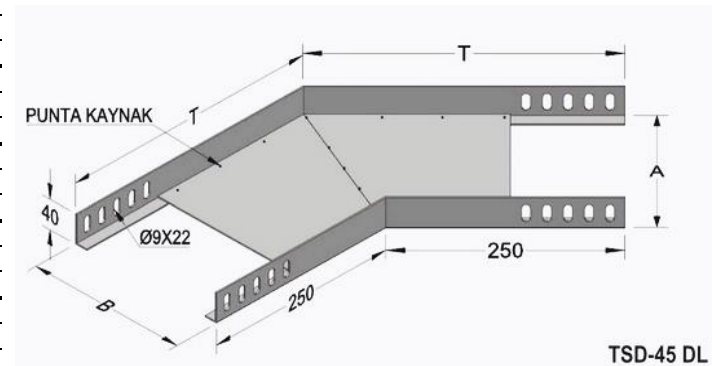

TSD-A60-45/5, TSD-B60-45, TSD-C60-45 PG, Горизонтальный угол 45°	600 мм	2	шт.	60	5,819
				100	6,484
				50	4,110
		1,2	шт.	60	4,300
				100	4,740
				50	5,138
	1,5	шт.	60	5,375	
			100	5,925	
			50	6,833	
	2	шт.	60	7,149	
			100	7,880	
			50		

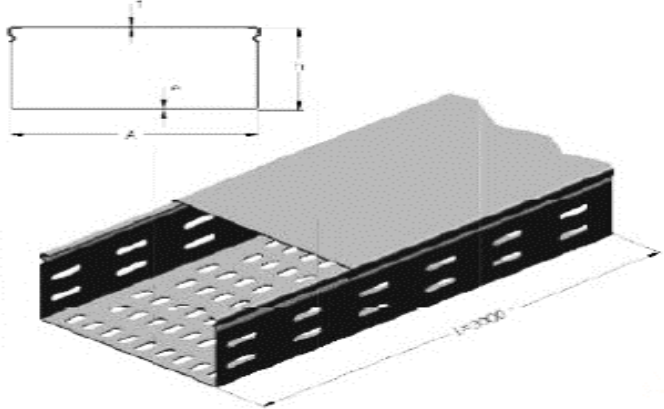
Кабельный лоток с выдвигающейся крышкой (PG)							
Наименование	A:	e:\t:	Ед.	h:	L: (мм)	Вес	
TSGKT-10, TSGKT-A10, TSGKT-B10 PG, Перфорированный кабельный лоток с крышкой	100 мм	1\0,8	метр	60	3000	2,267	
				70	3000	2,600	
				100	3000	2,800	
		1,5\1	метр	60	3000	3,400	
				70	3000	3,900	
				100	3000	4,200	
		2\1	метр	60	3000	4,533	
				70	3000	5,200	
				100	3000	5,600	
TSGKT-20, TSGKT-A20, TSGKT-B20 PG, Перфорированный кабельный лоток с крышкой	200 мм	1\0,8	метр	60	3000	3,780	
				70	3000	3,900	
				100	3000	4,267	
		1,5\1	метр	60	3000	5,670	
				70	3000	5,850	
				100	3000	6,400	
		2\1	метр	60	3000	7,560	
				70	3000	7,800	
				100	3000	8,533	
TSGKT-30, TSGKT-A30, TSGKT-B30 PG, Перфорированный кабельный лоток с крышкой	300 мм	1\0,8	метр	60	3000	5,260	
				70	3000	5,600	
				100	3000	6,075	
		1,5\1	метр	60	3000	7,890	
				70	3000	8,400	
				100	3000	9,113	
		2\1	метр	60	3000	10,520	
				70	3000	11,200	
				100	3000	12,150	
TSGKT-40, TSGKT-A40, TSGKT-B40 PG, Перфорированный кабельный лоток с крышкой	400 мм	1\0,8	метр	60	3000	6,500	
				70	3000	6,750	
				100	3000	7,200	
		1,5\1	метр	60	3000	9,750	
				70	3000	10,125	
				100	3000	10,800	
		2\1	метр	60	3000	13,000	
				70	3000	13,500	

					100	3000	14,400
TSGKT-50, TSGKT-A50, TSGKT-B50 PG, Перфорированный кабельный лоток с крышкой	500 мм	1,5\1	метр	60	3000	11,490	
				70	3000	11,813	
				100	3000	12,525	
		2\1,5	метр	60	3000	15,320	
				70	3000	15,750	
				100	3000	16,700	
TSGKT-60, TSGKT-A60, TSGKT-B60 PG, Перфорированный кабельный лоток с крышкой	600 мм	1,5\1	метр	60	3000	13,350	
				70	3000	13,500	
		2\1,5	метр	60	3000	17,800	
				70	3000	18,000	

**Аксессуары: Вертикальный Т-образный элемент (PG)**

Наименование	A:	e:	Ед.	h:	Вес
TSDTD-5/5, TSDTD-B5 PG, Вертикальный Т-образный элемент	50 мм	1	шт.	50	0,800
				60	0,900
		1,2	шт.	50	0,960
				60	1,080
		1,5	шт.	50	1,200
				60	1,350
TSDTD-10/5, TSDTD-B10, TSDTD-C10 PG, Вертикальный Т-образный элемент	100 мм	1	шт.	50	1,033
				60	1,200
				100	1,633
		1,2	шт.	50	1,240
				60	1,440
				100	1,960
		1,5	шт.	50	1,550
				60	1,800
				100	2,450
TSDTD-20/5, TSDTD-B20, TSDTD-C20 PG, Вертикальный Т-образный элемент	200 мм	1	шт.	50	1,867
				60	2,000
				100	2,520
		1,2	шт.	50	2,240
				60	2,400
				100	3,024



			1,5	шт.	60	3,000
					100	3,780
TSDTD-30/5, TSDTD-B30, TSDTD-C30 PG, Вертикальный T-образный элемент	300 мм	1,2	шт.	50	3,420	
				60	3,600	
				100	4,320	
		1,5	шт.	50	4,275	
				60	4,500	
				100	5,400	
		2	шт.	50	5,700	
				60	6,000	
				100	7,200	
TSDTD-40/5, TSDTD-B40, TSDTD-C40 PG, Вертикальный T-образный элемент	400 мм	1,2	шт.	50	4,890	
				60	5,016	
				100	5,790	
		1,5	шт.	50	6,113	
				60	6,270	
				100	7,238	
		2	шт.	50	8,150	
				60	8,360	
				100	9,650	
TSDTD-50/5, TSDTD-B50, TSDTD-C50 PG, Вертикальный T-образный элемент	500 мм	1,2	шт.	50	6,540	
				60	6,630	
				100	7,488	
		1,5	шт.	50	8,175	
				60	8,288	
				100	9,360	
		2	шт.	50	10,900	
				60	11,050	
				100	12,480	
TSDTD-60/5, TSDTD-B60, TSDTD-C60 PG, Вертикальный T-образный элемент	600 мм	1,2	шт.	50	8,400	
				60	8,448	
				100	9,396	
		1,5	шт.	50	10,500	
				60	10,560	
				100	11,745	
		2	шт.	50	14,000	
				60	14,080	
				100	15,660	

